

**Model RO-3C  
Model RO-3D**

# **Ion Chamber Technical Manual**

# MODELS RO-3C/RO-3D

## TABLE OF CONTENTS

Section	Page
I	GENERAL
	Purpose and Description . . . . . 1
	Specifications . . . . . 1
II	OPERATION
	Description of Controls . . . . . 3
	Using the Instrument . . . . . 3
III	THEORY OF OPERATION
	General . . . . . 5
	Functional Theory . . . . . 5
IV	MAINTENANCE
	Preventive Maintenance . . . . . 9
	Calibration . . . . . 9
	Disassembly . . . . . 9
	Reassembly . . . . . 11
	Troubleshooting . . . . . 11
V	PARTS LIST . . . . . 13
VI	DIAGRAMS . . . . . 15

## LIST OF ILLUSTRATIONS

Figure	Page
1-1	Ion Chamber, Model RO-3C . . . . . ii
1-2	Photon Energy Response . . . . . 2
3-1	RO-3C System Block Diagram . . . . . 7
3-2	RO-3D System Block Diagram . . . . . 8
4-1	Model RO-3C Interior View . . . . . 10
4-2	Model RO-3D Interior View . . . . . 10
6-1	Model RO-3C General Schematic . . . . . 15
6-2	Model RO-3D General Schematic . . . . . 16
6-3	Models RO-3C/RO-3D Chamber Component Layout . . . . . 17

## LIST OF TABLES

Table	Page
2-1	Altitude Corrections . . . . . 3
2-2	Temperature Corrections . . . . . 4
3-1	RO-3C Full Scale Currents and Voltages . . . . . 6
3-2	RO-3D Full Scale Currents and Voltages . . . . . 6
5-1	Range Switch Component Locations . . . . . 12

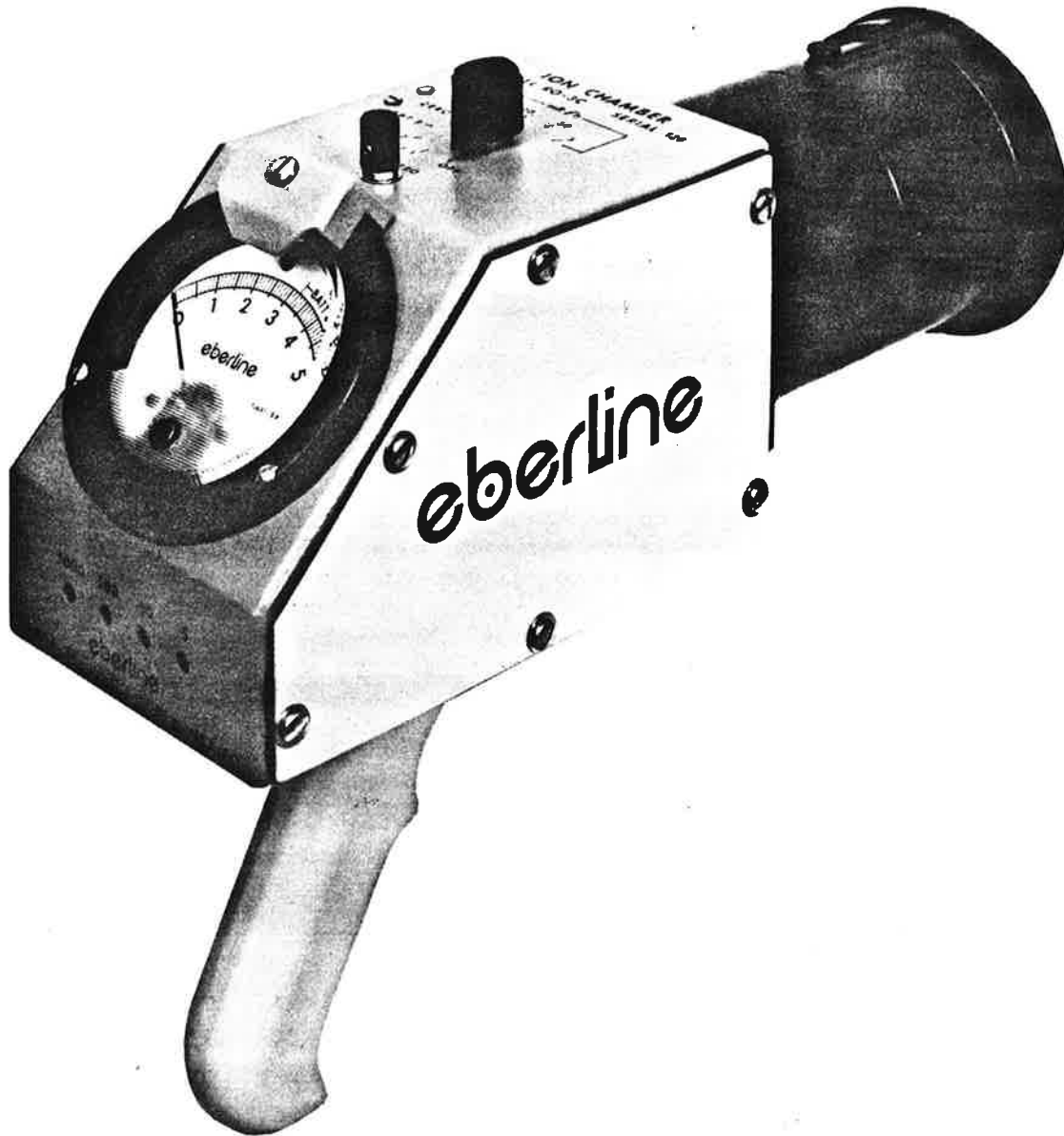

Figure 1-1. Model RO-3C Ion Chamber

## MODELS RO-3C/RO-3D

### SECTION I GENERAL

#### A. PURPOSE AND DESCRIPTION

The ion chambers, Models RO-3C and RO-3D are portable air ion chamber instruments used to detect beta, gamma and x-ray radiation. The RO-3C/-3D has four linear ranges of operation to measure dose rate. The ion chamber is vented to atmospheric pressure and is specifically designed to have flat energy response into the x-ray region. The Model RO-3C/-3D is sensitive to beta, gamma and x-ray and is calibrated to gamma radiation. A single rotary switch turns the instrument off, provides a battery check, checks the zero setting, and selects the range of operation.

The principal differences between the RO-3C and RO-3D are the ranges of operation. The RO-3D also includes multiple color-coded meter face scales and matching color-coded range switch positions. (See paragraph B.2.a. below). The center electrode in the chamber of the RO-3D is also larger to provide improved ion collection in the stronger radiation fields.

#### B. SPECIFICATIONS

##### 1. Detector

- a. Size: 3.25 inches (8.26 cm) o.d.  
RO-3C volume, 465 cm<sup>3</sup> (28.5 in<sup>3</sup>)  
RO-3D volume, 415 cm<sup>3</sup> (25.2 in<sup>3</sup>)
- b. Fill: Air, vented to atmospheric pressure.
- c. Wall: One-eighth inch phenolic, approximately 400 mg/cm<sup>2</sup>.
- d. Window: Aluminized, 0.001 inch Mylar®, approximately 3.5 mg/cm<sup>2</sup>.
- e. Beta Shield: Sliding shield on front of chamber secured by elastic bands. Approximately 400 mg/cm<sup>2</sup> (1/8-inch phenolic).
- f. Radiation Detected: Beta, gamma, x-ray.
- g. Fast Neutron Response: Reads approximately 10 percent in mR/h of true neutron field in mrem/h.
- h. Photon Energy Response: Nominal  $\pm 15$  percent from 6.5 keV to 1.2 MeV. (See Figure 1-2.)

##### 2. General

- a. Ranges:  
RO-3C: Four linear ranges: 0-5, 0-50, 0-500, 0-5000 mR/h.  
RO-3D: Four linear ranges:  
0-100 mR/h, coded red  
0-1000 mR/h, coded green  
0-10 R/h, coded blue  
0-100 R/h, coded red
- b. Meter: Ruggedized, sealed, 2.38 inch (6.05 cm) scale length, 2 percent accuracy MIL-SPEC type. Linear markings with 50 minor increments.
- c. Response Time: 5 seconds, 0 to 90 percent of reading.
- d. Linearity: Within  $\pm 5$  percent of full scale.
- e. Battery Dependence: No calibration shift with battery voltage change (down to *BATT* check mark on meter).
- f. Controls
  - (1) Range switch with *OFF*, *ZERO* and battery checking positions.
  - (2) The *ZERO* knob is used to set the meter to zero when the *ZERO* position of the range switch is selected, or when it is in no significant radiation field.
  - (3) Calibration controls, one for each range.
  - (4) Light switch, controls meter lights.
- g. Batteries  
RO-3C: Five NEDA 1604 9 V type.  
Approximate Life:  
Two, indefinitely long  
Two, 200 hours, C-Zn  
One, 10 hours, C-Zn, meter lights  
RO-3D: Three NEDA 1604 9 V type.  
One NEDA 213 45 V type.  
Approximate Life:  
Two 1604, 200 hours, C-Zn  
One 1604, 10 hours, C-Zn meter lights  
The 213, indefinitely long

MODELS RO-3C/RO-3D

h. Environment

(1) Temperature: Operable from  $-40^{\circ}\text{F}$  to  $140^{\circ}\text{F}$  ( $-40^{\circ}\text{C}$  to  $60^{\circ}\text{C}$ ). (Operation at low temperatures may be limited by battery performance.)

(2) Moisture: Seals used at openings for dust and water resistance. Detector is protected by a silica-gel drying box.

i. Weight: Approximately 4 pounds (1.8 kg), including C-Zn batteries.

j. Size:  $4\frac{1}{8}$  inches wide x  $11\frac{3}{8}$  inches long x  $8\frac{3}{4}$  inches high (10.5 cm x 28.9 cm x 22.2 cm), including handle.

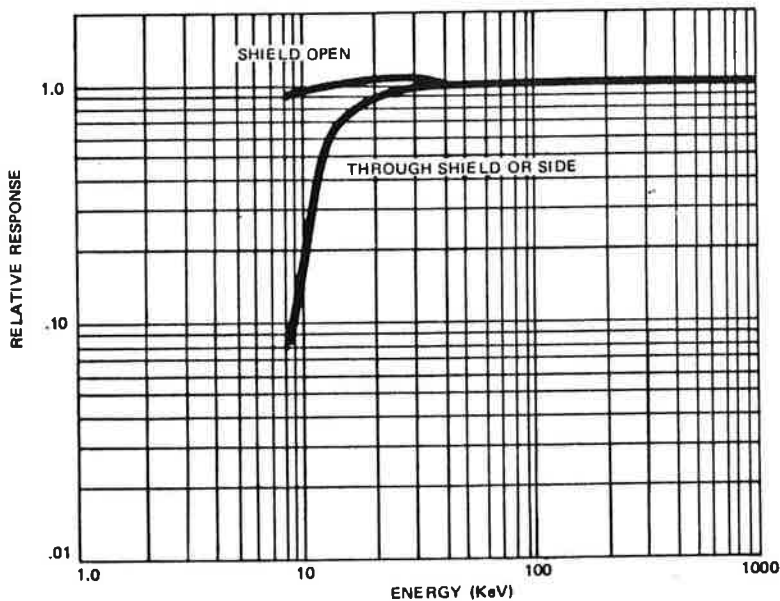

Figure 1-2. Photon Energy Response

## SECTION II OPERATION

### A. DESCRIPTION OF CONTROLS

**1. Function Switch:** Nine-position rotary switch that turns the instrument off, checks the condition of the batteries, checks instrument zero, and selects the range of operation to be used.

**2. ZERO Knob:** Used to set the meter to zero when the *ZERO* switch position is selected or when in an insignificant radiation field.

**3. Calibration Controls:** Four variable resistors, one for each range.

**4. Light Switch:** Spring-loaded toggle switch located forward of the handle. It operates the meter lamps.

### B. USING THE INSTRUMENT

1. Turn the function switch to *BAT 1*, *BAT 2*, and then to *BAT 3* positions. The meter should read above the *BATT* cut-off line in all cases.

2. Turn the function switch to the *ZERO* position. Check that the meter reads zero. If not, set it to zero with the *ZERO* knob.

3. Set the function switch to the desired range of operation. The switch position selected is the full scale reading of that range.

4. When measuring beta or low energy gamma or x-ray emissions, open the sliding beta shield and face the instrument toward the radiation source. When the shield is open, protect the thin face against damage by puncture.

### NOTES

- a. The zero setting of the instrument may be checked in any radiation field by merely selecting the *ZERO* position.
- b. When selecting the most sensitive range on the RO-3C, 5 mR/h, switching transient noise may cause a temporary deflection of the meter. This can be avoided by first selecting 50 mR/h, letting the needle settle, and then switching to 5 mR/h.
- c. Since the ion chamber is vented to atmospheric pressure, it is sensitive to changes in both air pressure and temperature. Tables 2-1 and 2-2 give correction factors to be used if the use conditions are different from the calibration conditions. If both pressure and temperature are different, multiply the meter reading by both factors.

		ALTITUDE WHEN CALIBRATED										
		SEA LEVEL	1000'	2000'	3000'	4000'	5000'	6000'	7000'	8000'	9000'	10,000'
ALTITUDE WHEN USED	SEA LEVEL	1	0.96	0.93	0.90	0.86	0.83	0.80	0.77	0.74	0.71	0.69
	1000'	1.04	1	0.96	0.93	0.90	0.86	0.83	0.80	0.77	0.74	0.71
	2000'	1.08	1.04	1	0.96	0.93	0.89	0.86	0.83	0.80	0.77	0.74
	3000'	1.12	1.08	1.04	1	0.96	0.93	0.89	0.86	0.83	0.80	0.77
	4000'	1.16	1.12	1.08	1.04	1	0.96	0.93	0.89	0.86	0.83	0.80
	5000'	1.20	1.16	1.12	1.08	1.04	1	0.96	0.93	0.89	0.86	0.83
	6000'	1.25	1.20	1.16	1.12	1.08	1.04	1	0.96	0.93	0.89	0.86
	7000'	1.30	1.25	1.20	1.16	1.12	1.08	1.04	1	0.96	0.93	0.89
	8000'	1.35	1.30	1.25	1.21	1.16	1.12	1.08	1.04	1	0.96	0.93
	9000'	1.40	1.35	1.30	1.25	1.21	1.16	1.12	1.08	1.04	1	0.96
	10,000'	1.45	1.40	1.35	1.30	1.26	1.21	1.17	1.12	1.08	1.04	1

MULTIPLY METER READING BY GIVEN CORRECTION FACTOR

*Table 2-1. Altitude Corrections*

		TEMPERATURE WHEN CALIBRATED																				
		40	-40	-34.4	-28.9	-23.3	-17.8	-12.2	-6.7	-1.1	4.4	10	15.6	21.1	26.7	32.2	37.8	43.3	48.9	54.4	60	
		°F	°F	°F	°F	°F	°F	°F	°F	°F	°F	°F	°F	°F	°F	°F	°F	°F	°F	°F	°F	°F
TEMPERATURE WHEN USED	-40	1	0.98	0.95	0.93	0.91	0.89	0.87	0.85	0.84	0.83	0.81	0.79	0.78	0.76	0.75	0.73	0.71	0.70	0.70	0.70	0.70
	-34.4	-20	1.02	1	0.98	0.96	0.94	0.92	0.90	0.88	0.86	0.84	0.83	0.81	0.80	0.79	0.77	0.76	0.75	0.75	0.75	0.75
	-28.9	-10	1.05	1.02	1	0.98	0.96	0.94	0.92	0.90	0.88	0.87	0.85	0.83	0.82	0.80	0.79	0.78	0.78	0.78	0.78	0.77
	-23.3	0	1.07	1.05	1.02	1	0.98	0.96	0.94	0.92	0.90	0.88	0.87	0.85	0.84	0.82	0.81	0.79	0.78	0.78	0.78	0.77
	-17.8	10	1.10	1.07	1.05	1.02	1	0.98	0.96	0.94	0.92	0.90	0.88	0.87	0.85	0.84	0.82	0.81	0.79	0.78	0.78	0.78
	12.2	20	1.12	1.09	1.07	1.04	1.02	1	0.98	0.96	0.94	0.92	0.90	0.89	0.87	0.85	0.84	0.82	0.81	0.80	0.80	0.80
	-6.7	30	1.14	1.12	1.09	1.07	1.04	1.02	1	0.98	0.96	0.94	0.92	0.91	0.89	0.87	0.86	0.84	0.83	0.81	0.80	0.80
	-1.1	40	1.17	1.14	1.11	1.09	1.07	1.04	1.02	1	0.98	0.96	0.94	0.92	0.91	0.89	0.87	0.86	0.84	0.83	0.81	0.80
	4.4	50	1.19	1.16	1.14	1.11	1.09	1.07	1.06	1.04	1.02	1	0.98	0.96	0.94	0.93	0.91	0.89	0.87	0.86	0.85	0.83
	10	60	1.21	1.19	1.16	1.13	1.11	1.09	1.08	1.06	1.04	1.02	1	0.98	0.96	0.95	0.93	0.91	0.89	0.88	0.86	0.85
	15.6	70	1.24	1.21	1.18	1.16	1.13	1.11	1.08	1.06	1.04	1.02	1	0.98	0.96	0.95	0.93	0.91	0.89	0.88	0.86	0.85
	21.1	80	1.26	1.23	1.20	1.18	1.15	1.13	1.10	1.08	1.06	1.04	1.02	1	0.98	0.96	0.95	0.93	0.91	0.89	0.88	0.87
	26.7	90	1.29	1.26	1.23	1.20	1.17	1.15	1.13	1.10	1.08	1.06	1.04	1.02	1	0.98	0.96	0.95	0.93	0.91	0.89	0.88
	32.2	100	1.31	1.28	1.25	1.22	1.20	1.17	1.15	1.12	1.10	1.08	1.06	1.04	1.02	1	0.98	0.96	0.95	0.93	0.92	0.90
	37.8	110	1.33	1.30	1.27	1.24	1.22	1.20	1.17	1.15	1.12	1.10	1.08	1.06	1.04	1.02	1	0.98	0.96	0.95	0.93	0.92
	43.3	120	1.36	1.33	1.30	1.27	1.24	1.22	1.19	1.17	1.14	1.12	1.10	1.08	1.06	1.04	1.02	1	0.98	0.97	0.95	0.93
48.9	130	1.38	1.35	1.32	1.29	1.26	1.23	1.21	1.19	1.16	1.14	1.12	1.10	1.08	1.06	1.04	1.02	1	0.98	0.97	0.95	
54.4	140	1.41	1.37	1.34	1.31	1.28	1.26	1.23	1.21	1.18	1.16	1.14	1.12	1.09	1.07	1.05	1.04	1.02	1	0.98	0.97	
60	140	1.43	1.40	1.36	1.33	1.30	1.28	1.25	1.22	1.20	1.18	1.16	1.13	1.11	1.09	1.07	1.05	1.04	1.02	1	0.98	

MULTIPLY METER READING BY GIVEN CORRECTION FACTOR

Table 2-2. Temperature Corrections

## SECTION III THEORY OF OPERATION

### A. GENERAL

Refer to Figures 3-1 and 3-2, the block diagrams representing the basic operation of the circuits. The ion chamber has battery potential between the inside wall and the center electrode. When the air in the chamber ionizes due to radiation, a minute current flows through the chamber causing the minus input lead of the operational amplifier to go very slightly positive. This results in a negative swing of the amplifier output which is connected to the feedback elements through a divider circuit. The feedback elements are connected to the amplifier input and ion chamber and they conduct away all of the current generated in the ion chamber. The meter is also tied to the output of the amplifier and indicates in proportion to amplifier output voltage. Range changing is done by selecting different feedback elements and by selecting different points on the feedback divider.

### B. FUNCTIONAL THEORY

#### 1. Ion Chamber

The ion chamber is mounted on the front of the instrument case. It consists of the forward 3.68 inches (9.35 cm) of the 3/4-inch-diameter chamber assembly. The remainder of the volume contains electronic components, including the amplifier A1. The chamber wall is 1/8-inch (0.32 cm) phenolic, and the face is 1-mil aluminized Mylar®. The active volume of the RO-3C chamber is 465 cm<sup>3</sup> (28.5 in<sup>3</sup>), and the volume in the RO-3D chamber is 415 cm<sup>3</sup> (25.2 in<sup>3</sup>).

The inside and outside surfaces of the chamber walls have a conductive coating of graphite dag which is maintained at ground (case) potential. The inside of the aluminized Mylar® face is also at ground potential. The common return (*GND*) of the amplifier is maintained at a negative potential with respect to the chassis (18 V in the RO-3C, 45 V in the RO-3D) to provide chamber current. The center electrode is coated with conductive dag and is supported on the center conductor of the guarded feedthrough at the back of the chamber. The guard ring of the guarded feedthrough is positioned on insulators between the center conductor and the grounded outer ring to prevent possible leakage from the chamber wall to the center electrode. The guard ring and center electrode are maintained at the same potential so no leakage from the guard to the electrode will occur.

The chamber is sealed, except for a small hole in the inner wall which vents it to the electronic section

immediately behind the chamber. This section is vented to the inside of the main instrument case through a plastic hose connected to a drying box filled with silica gel desiccant. In this way, any air drawn into the chamber (caused by atmospheric pressure changes, temperature changes, transporting the RO-3C/-3D by air, etc.) must first pass over the drying desiccant. Dry air in the chamber is necessary to help prevent leakage.

An idealized air chamber, the size of the one used on the Model RO-3C, produces approximately 4.31 x 10<sup>-14</sup> A per mR/h at standard temperature and pressure (STP is 0 °C and sea level pressure of 760 mm of Hg). At 5 mR/h it should produce 2.15 x 10<sup>-13</sup> A, and at 5000 mR/h it should produce 2.15 x 10<sup>-10</sup> A. It is seen that at full scale on the most sensitive range of the RO-3C (5 mR/h), about one-fifth of a micro-microamp is produced in the chamber, which makes protection against leakage current paramount. The silica gel desiccant should be changed as soon as it shows any clear or pink crystals.

#### 2. Operational Amplifier (See Figure 6-1 or 6-2)

The operational amplifier, A1, is contained in a single TO-5 size transistor package located behind the chamber assembly. It has dual MOS FET inputs which results in a very high input impedance, on the order of 10<sup>15</sup> Ω. The non-inverting input, pin 3, is connected to amplifier *GND* and the other input, pin 2, is connected to the ion chamber center electrode and the feedback elements. The output of the amplifier, pin 6, feeds the meter circuit.

When ion chamber current flows toward the amplifier input at pin 2, the input becomes slightly more positive, which causes the output to go more negative. This negative output of the amplifier draws a current from one of the feedback elements to exactly match the amount of current the ion chamber is contributing. If a higher ion chamber current occurs, the amplifier must produce a higher voltage across the feedback element to draw off the current. In this way, the amplifier voltage output is proportional to the chamber current which is, in turn, proportional to the rate of radiation in the chamber.

#### 3. Meter Circuit

The meter is driven directly from the output of the amplifier, pin 6, through dropping resistor R8 and one of four calibrating resistors, R9 through R12. Nominally, the meter reaches full scale on all ranges at approximately the same voltage output from the amplifier. The

MODELS RO-3C/RO-3D

four calibrating resistors allow for manufacturing tolerances in various components and provide for calibration at various elevations and temperatures. Function switch S1, section C, determines which calibration resistor is in the circuit.

4. Range Switching

The range that the Model RO-3C/D is operating on depends entirely on the feedback circuitry between the output of the amplifier and the amplifier input, pin 2, which is connected to the ion chamber. Tables 3-1 and 3-2 show the nominal current and voltage conditions of the circuit when at full scale on the four ranges (sea level, 0° C).

Feedback resistor R1 is connected to the circuit at all times. When using the two higher ranges, S2 closes and R2 is put into the circuit. Since R2 has 100 times less resistance than R1, the effect of R1 is negligible. When on the ZERO or OFF positions of the range switch, S3 closes and shorts out the feedback resistors so that the feedback current cannot generate any voltage across the resistors. When this occurs, any voltage remaining on the amplifier output and showing on the meter is zero offset error. This offset can be removed with the ZERO control, R3, which rebalances the amplifier with both inputs of A1 at amplifier ground potential.

Switches S2 and S3 are glass encapsulated magnetic reed switches with a very high open circuit impedance. They are activated by four permanent magnets which move on a disc on the outside of the chamber assembly. S3, the shorting switch, is located in the top of the chamber assembly. A magnet is near S3 when the range switch is at OFF or ZERO. S2, the switch that places R2 in the circuit, is located in the bottom of the chamber assembly. A magnet is near S2 when the range switch is at the two higher range positions. When using the two lower range positions, the magnets are away from the chamber and neither S2 nor S3 is pulled in. This leaves R1 as the active resistor.

The second section of S1 (S1-B) selects full amplifier output voltage, or a percentage of that voltage to supply the feedback elements. In the RO-3C, full amplifier voltage is used on the 5000, 50, BAT 1, BAT 2 and BAT 3 positions and one-tenth output voltage is used on the 500, 5 and ZERO positions. In the RO-3D, full amplifier voltage is used on the 1000 mR/h, BAT 1, BAT 2 and BAT 3 positions and one-tenth output voltage is used on the 100 mR/h, 10 R/h and ZERO positions. The 100 R/h position uses 80 percent of amplifier output to get a boosted output for the high range.

RANGE SETTING	ION CHAMBER CURRENT, AMPS FULL SCALE	FEEDBACK ELEMENT	VOLTAGE ON FEEDBACK ELEMENT	VOLTAGE OUT OF AMPLIFIER
5 mR/h	$2.15 \times 10^{-13}$	R1, $1 \times 10^{12}$ ohm	0.215	2.15
50 mR/h	$2.15 \times 10^{-12}$	R1, $1 \times 10^{12}$ ohm	2.15	2.15
500 mR/h	$2.15 \times 10^{-11}$	R2, $1 \times 10^{10}$ ohm	0.215	2.15
5000 mR/h	$2.15 \times 10^{-10}$	R2, $1 \times 10^{10}$ ohm	2.15	2.15

Table 3-1. RO-3C Full Scale Currents and Voltages

RANGE SETTING	ION CHAMBER CURRENT, AMPS FULL SCALE	FEEDBACK ELEMENT	VOLTAGE ON FEEDBACK ELEMENT	VOLTAGE OUT OF AMPLIFIER
100 mR/h	$3.84 \times 10^{-12}$	R1, $5 \times 10^{10}$	0.192	1.92
1000 mR/h	$3.84 \times 10^{-11}$	R1, $5 \times 10^{10}$	1.92	1.92
10 R/h	$3.84 \times 10^{-10}$	R2, $5 \times 10^8$	0.192	1.92
100 R/h	$3.84 \times 10^{-9}$	R2, $5 \times 10^8$	1.92	2.40

Table 3-2. RO-3D Full Scale Currents and Voltages

MODELS RO-3C/RO-3D

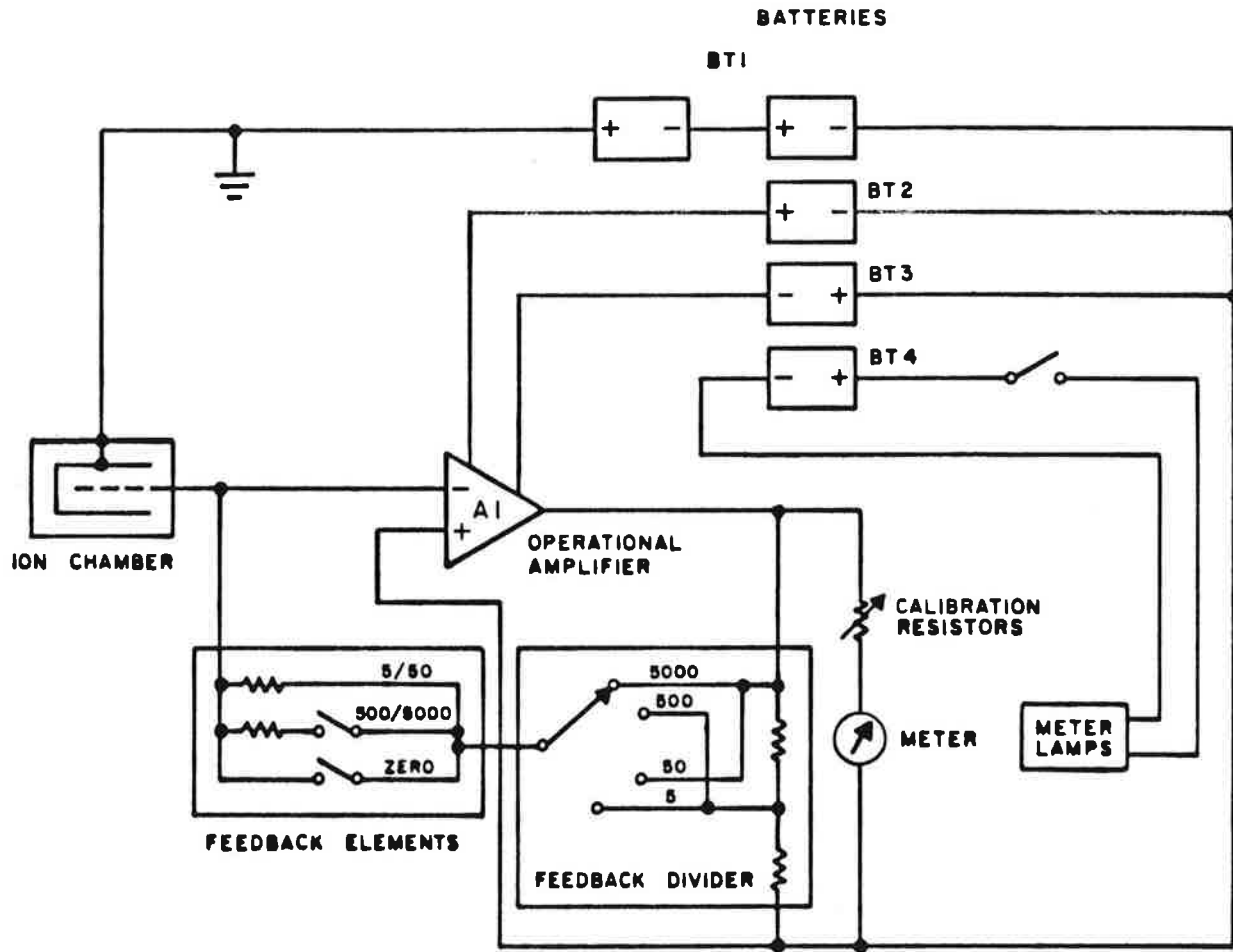

Figure 3-1. RO-3C System Block Diagram (11252-B06)

MODELS RO-3C/RO-3D

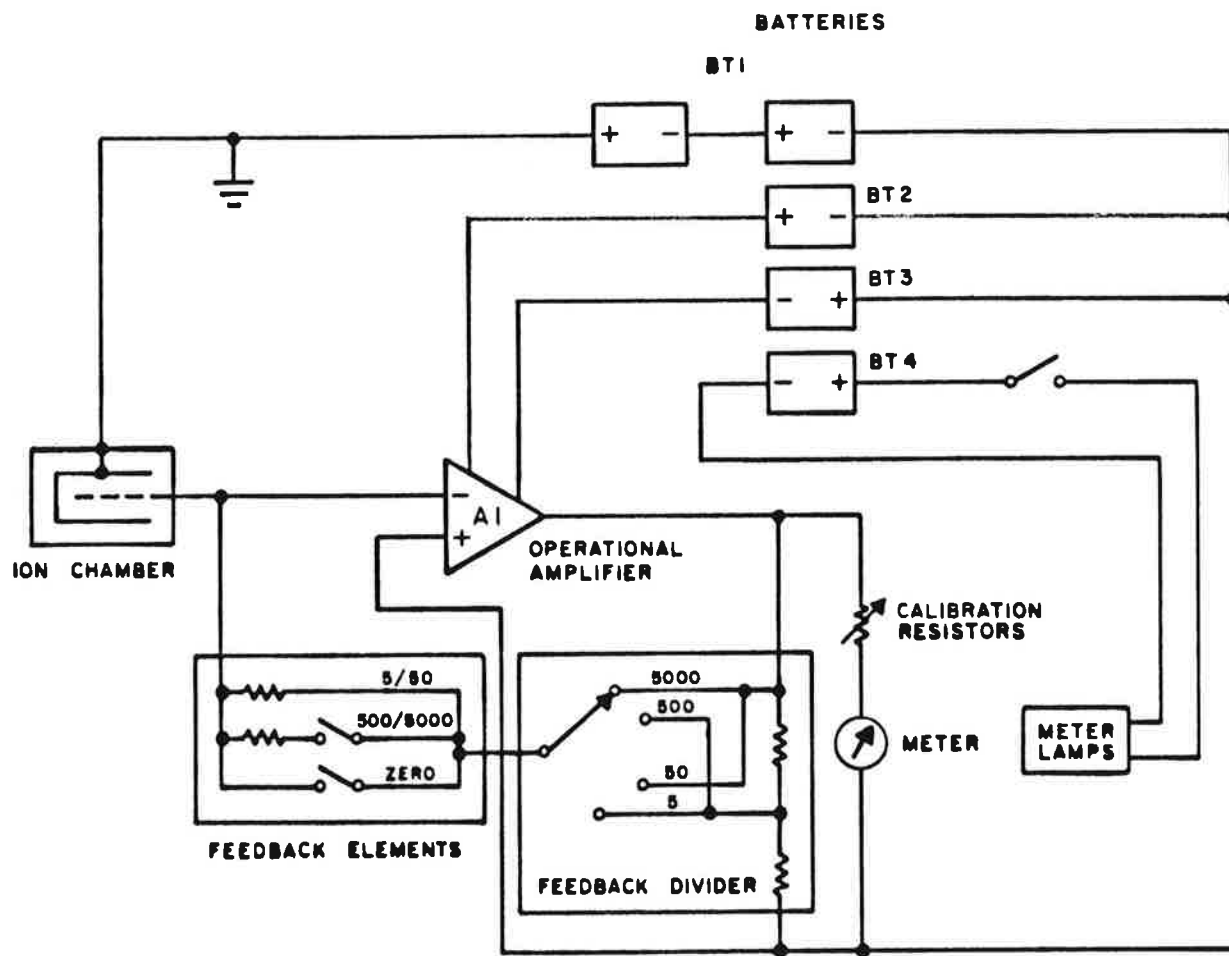

Figure 3-1. RO-3C System Block Diagram (11252-B06)

MODELS RO-3C/RO-3D

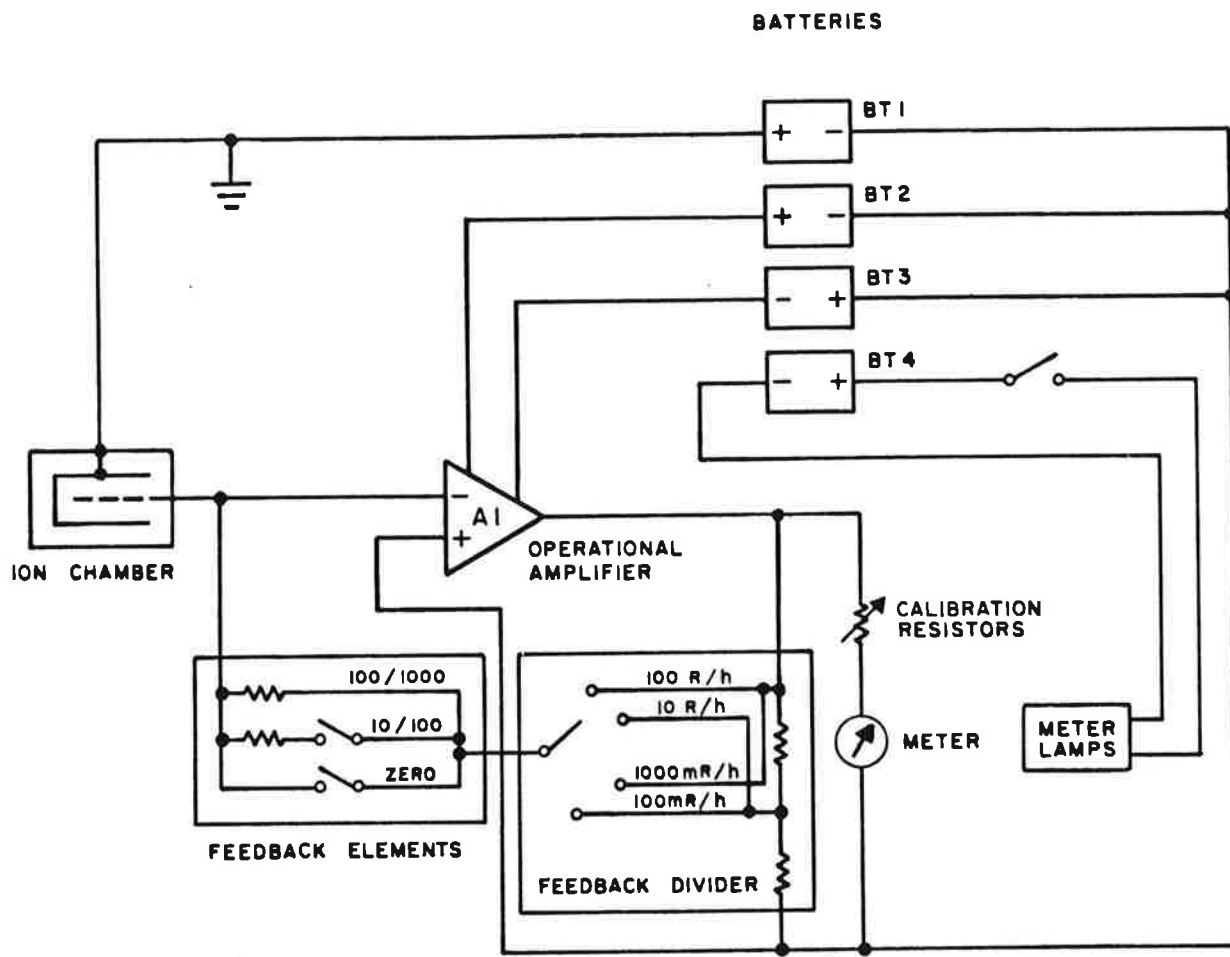

Figure 3-2. RO-3D System Block Diagram (11253-B09)

## SECTION IV MAINTENANCE

### A. PREVENTIVE MAINTENANCE

1. Replace the batteries when, during battery check, the meter indicates at or below the left end of the *BATT OK* line on the meter face. The batteries are accessible by removing the side covers. Batteries may be replaced individually or in pairs. In the RO-3C, *BAT 1* checks the two 9 V batteries on the right hand side and in the RO-3D, *BAT 1* checks the single 45 V battery on the right hand side. *BAT 2* and *BAT 3* check the two batteries on the chassis floor on the left. In normal use it will be necessary to replace the *BAT 2* and *BAT 3* batteries more often than the *BAT 1* battery. The *BAT 2* and *BAT 3* batteries supply the amplifier, A1, and have a life of 200 to 400 hours, depending upon battery type, age, etc. The *BAT 1* battery supplies only the ion chamber current; therefore, it lasts indefinitely long (shelf-life). The meter lamp battery, located on the left side beside the range switch, should be replaced as required.

2. Remove the batteries if the instrument is to be inactive for a long period.

3. Dry or replace the desiccant crystals when they first begin to turn clear or pink in color. To remove the desiccant box, remove side covers and open the nylon retaining straps that hold the box. Remove the tape from around the box lid. When new or dried crystals are in place in the box, retape the lid to the box and reinstall. Do not seal the box completely with tape. Leave a small space so that air can enter and leave the box. The desiccant crystals can be repeatedly dried by heating to 250 °F (121 °C) for 12 hours or to 400 °F (204 °C) for one hour. Do not heat the plastic box. The desiccant life will be prolonged if the box is placed in a small plastic bag with a rubber band closing the bag around the plastic hose.

### NOTE

It is very important that the inside of the chamber assembly be kept dry to avoid leakage currents due to moisture. If the desiccant becomes saturated and the RO-3C/-3D becomes erratic due to moisture, renew the desiccant crystals and cycle the instrument between room temperature (or lower) and +140 °F (60 °C) three or four times to flush the chamber air across the desiccant.

### B. CALIBRATION

For maximum accuracy, the RO-3C/-3D should be calibrated at approximately the same temperature and air pressure as is expected for its use. If the conditions for calibration and for use are necessarily different, an offset may be used during calibration so that the instrument will read properly when put into use. Tables 2-1 and 2-2, Section II, may be used to select the proper offset in this case.

To calibrate, position the RO-3C/-3D so that the ion chamber is in a gamma field of known intensity. Adjust the calibration control (corresponding to the range switch position) for the proper meter indication. For best accuracy, choose a calibration field strength that will cause the meter to read about 3/4 full scale when calibrated. Repeat the procedure for all ranges. To avoid errors, the entire ion chamber of the RO-3C/-3D must be in the gamma field when calibrating. The effective center of the chamber is marked by a groove around the outside about 2 inches from the front end.

### WARNING

The gamma field intensities required for the complete calibration of the RO-3C/-3D are potentially hazardous to personnel. Observe proper precautions to prevent injury.

### C. DISASSEMBLY

1. To remove case covers, remove the six 6-32 screws that secure the cover to the case. A rubber gasket is used between the cover and the case. No glue is used between the gasket and the case; however, the rubber may take a "set" and adhere to the case. Pry gently between case and rubber gasket if necessary to remove the cover.

### CAUTION

The amplifier, A1, is highly susceptible to damage from static charges. When side covers are removed, take care that no item, including batteries, be brought in contact with the RO-3C/-3D assembly that has not first been grounded to the chassis of the RO-3C/-3D. Grasping the case of the RO-3C/-3D with one hand and touching the item

MODELS RO-3C/RO-3D

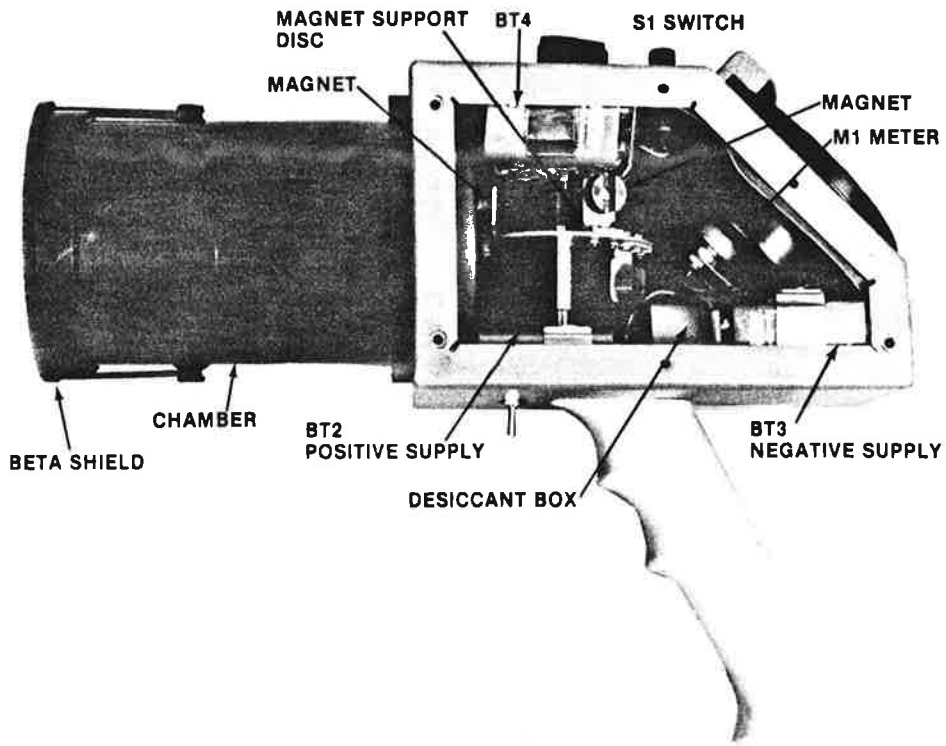

Figure 4-1. Model RO-3C Interior View

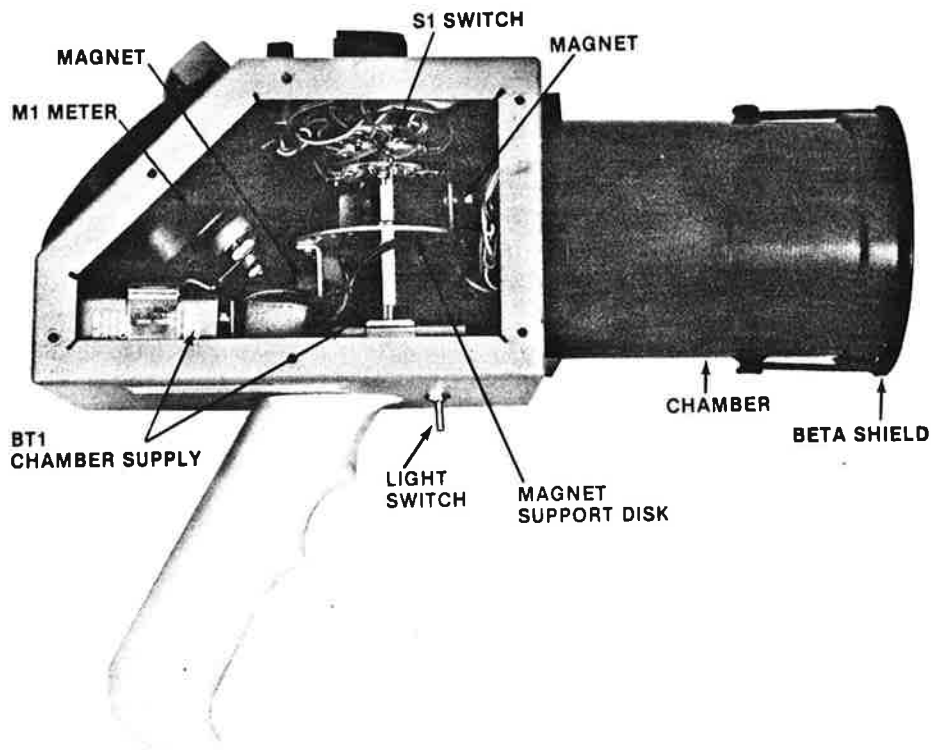

Figure 4-2. Model RO-3C Interior View

## MODELS RO-3C/RO-3D

concerned with the other should eliminate any static charge. Soldering irons must be clipped to ground prior to touching any part of the RO-3C/-3D. For added protection when working on the instrument, remove batteries and clip chamber terminals 1, 3, 4, 7, and 8 (counting clockwise with chamber face toward viewer) together. Remove clips before reinstalling batteries.

2. The batteries may be removed by gently prying the battery out of the spring clip holder. The battery connectors are "snap" type.

3. To remove the dessicant box, first remove BT2 and BT3 batteries from the left side of the instrument and turn the switch approximately 180° to move the magnets out of the way. Next unplug the plastic tube at the side of the chamber, pull open the nylon retaining straps, and remove the box from the left side. **CAUTION:** Avoid snagging the plastic bag around the box during removal or replacement. Use long nose pliers to reconnect the plastic tube when replacing the box.

4. The chamber assembly may be removed by removing four 6-32 screws in the chamber assembly flange. Tilt the chamber assembly to the right, so as to clear the electrical connections, and remove the chamber assembly.

5. To remove the switch assembly and *ZERO* potentiometer, remove knobs and bushing nuts. Disconnect the two wires to the meter and drop the lower switch bearing by loosening the bushing nut. Switch assembly, *ZERO* pot and bracket may be removed from either side of the case or through the front opening if the chamber assembly has been removed. If it is necessary to remove the magnet support disc, mark the position of the disc on the shaft so that it can be replaced accurately.

6. The meter may be removed by disconnecting wires to the meter and removing the three 6-32 screws in the meter bezel. This frees the meter.

7. To remove the calibration potentiometers, remove the four 4-40 nuts securing the calibration potentiometer bracket to the case and lift out as a unit. Potentiometers may be removed from the bracket by unsoldering the wires and removing the bushing nut.

8. To gain access to the detector electronics, once the chamber assembly has been removed from the case, remove the retaining ring and end plate at the rear of the chamber assembly. The end plate has a small notch on the edge in which a small screwdriver may be inserted as an aid in removal. Observe caution paragraph above. Cleanliness inside the chamber assembly is of the utmost importance.

9. The inside of the ion chamber can be reached by removing the chamber face ring and then removing the chamber face. Once the face is removed, the center electrode may be removed by unscrewing it from the center pin. If the pin starts to rotate, hold it with pliers applied in the electronic section.

### D. REASSEMBLY

1. In general, for reassembly reverse the procedure used in disassembly.

2. The chamber face, as supplied, is 1-mil-thick (0.001-inch) aluminized Mylar® film. To replace the film, simply place a new film over the chamber opening and carefully press the chamber face ring down over the film until the ring seats firmly. The excess film may be trimmed with a very sharp knife or other very sharp instrument. If only one side of the Mylar® is aluminized, make sure that the aluminized side is toward the inside of the chamber so that proper electrostatic fields can be maintained. A chamber face as thick as 2 mil (0.002 inch) or as thin as ¼ mil (0.00025 inch) may be used.

In very humid conditions, it may be desirable to flush the chamber with dry nitrogen just prior to closing it with the face. If this is not done it may be necessary to temperature cycle the unit later as described in part A of this section.

3. The magnet support disc should be adjusted such that the edge of the disc is in line with the center of the chamber assembly, the top magnets are directly behind the chamber in the *OFF* and *ZERO* positions of the selector switch, and the bottom magnets are directly behind the chamber assembly in the two highest range positions of the selector switch. One method of checking rotational alignment is to place the selector switch in the *ZERO* position and then bring a check source near the chamber. If the meter reads upscale with the check source near the chamber, the magnet support disc is not properly aligned. A hole in the selector switch shaft has been provided to accept the point of the set screw.

### E. TROUBLESHOOTING

The schematic diagrams, Figures 6-1 and 6-2; the system block diagrams, Figures 3-1 and 3-2; and Section III, "Theory of Operation," are the primary aids to troubleshooting.

1. The RO-3C/-3D has no active electronic components except for the amplifier, A1. The most likely sources of trouble, then, would be the amplifier, a broken wire, poor batteries or leakage in the high impedance areas of the chamber assembly.

## MODELS RO-3C/RO-3D

2. If the meter remains pegged and will not zero when the *ZERO* position is selected, check for proper battery voltages. Using the schematic, Figure 6-1 or 6-2 as a guide, check for proper voltages at the chamber assembly terminals. Terminal 1 should be at chassis ground potential, 2 and 6 should be slightly less negative than terminal 7. Pin 3 should be negative with respect to the chassis by an amount equal to BT1. Pin 4 should be positive with respect to pin 3, and pin 7 negative with respect to pin 3 by BT2 and BT3 voltages, respectively. If these voltages appear normal, but terminals 5 and 8 are of the same potential, the amplifier should be changed. Observe how the old amplifier was installed and install the new one in the same way.

3. Since the amplifier can be completely destroyed by as insignificant an act as touching it improperly, every possible precaution should be taken to make sure that all static charges are eliminated around the unit. Do not remove the shorting device shipped with the new amplifier until other shorting clips are in place. Leave the clips in place until the amplifier is soldered in. Then transfer the clip to the terminal or other place where the lead was soldered until installation is complete. Make

sure that the soldering iron is grounded not only to instrument chassis ground, but also to the shorting clip around the amplifier when soldering first starts.

### 4. High Impedance Components

Several components connect to the point in the circuit where the extremely minute ion chamber current flows. It is of utmost importance that they be clean, free of fingerprints and carefully installed. They include pin 2 of A1, the two feedback resistors R1 and R2, and the two reed switches S2 and S3. The leads of these components are not supported on insulators. They are air insulated at all points. All wiring in the chamber assembly should be dressed away from the high impedance components.

If leakage currents appear to be a problem, make sure the silica gel in the desiccant box is dark blue. Temperature cycling as described in the note in part A of this section may correct the problem. The use of a high purity, mild, Freon® solvent spray to clean the high impedance components may help. Do not use an alcohol spray since it will dissolve the dag coating used in the assembly.

REFERENCE DESIGNATION	VALUE	LOCATION ON SWITCH (TOP VIEW)
C4	180 $\mu$ F	Right Front
R4 (RO-3C)	1M	Left Front
R4 (RO-3D)	200k	Left Rear
R5	110k	Right Rear
R6	91k	Right Side
R7	91k	Right Side
R8	10k	Left Front
R13 (RO-3C)	130k	Left Front
R13 (RO-3D)	330k	Left Front
R14	2.4k	Right Front
R15 (RO-3C)	10M	Right Side
R15 (RO-3D)	820k	Left Side
R16 (RO-3D)	10M	Right Side

*Table 5-1. Range Switch Component Locations*

## SECTION V PARTS LIST

The following table lists the electronic items incorporated in the RO-3C/-3D and should contain any part necessary for normal electronic repair. Unless otherwise specified, callouts of manufacturers and manufacturers' part numbers are to be considered typical examples only and not restrictions against using equivalent parts with the same operating characteristics. When ordering parts from Eberline, specify model number, serial number, reference designation, value, Eberline part number, or a word description if the part has no reference designation. Eberline will automatically substitute equivalent parts when the one called out by the manufacturers' part number is not available.

REF DESIG	PART	DESCRIPTION	MANUFACTURER AND PART NUMBER	EBERLINE PART NUMBER
A1	Amplifier	MOS FET Input		ICAOC07463
BT1 (RO-3C)	Battery	2 NEDA 1604, 9 V Type	Eveready 216 or equivalent	BTCZ1
BT1 (RO-3D)	Battery	NEDA 213, 45 V Type	Eveready 415 or equivalent	BTCZ5
BT2, BT3, BT4	Battery	NEDA 1604, 9 V Type	Eveready 216 or equivalent	BTCZ1
C1, C2, C3 C4	Capacitor Capacitor	0.1 $\mu$ F, 10%, 80 V 180 $\mu$ F, 10%, 10 V	Sprague 192P1049R8 Kemet K180A10K	CPPF104P30 CPTA181M4F
DS1, DS2	Lamp	5 V, 21 mA, T 3/4	#2	LPBU13
M1	Meter	50 $\mu$ A with face number 10695-B47 for RO-3C or 10472-B96 for RO-3D	Triplett 321-HR	MTPA6 ZP10695047 ZP10472096
R1 (RO-3C)	Resistor	1 x 10 <sup>12</sup> , 10%	Victoreen RX-1 HI-MEG	REHV102G3X
R1 (RO-3D)	Resistor	5 x 10 <sup>10</sup> , 10%	Victoreen RX-1 HI-MEG	REHV500G3X
R2 (RO-3C)	Resistor	1 x 10 <sup>10</sup> , 10%	Victoreen RX-1 HI-MEG	REHV100G3X
R2 (RO-3D)	Resistor	5 x 10 <sup>8</sup> , 10%	Victoreen RX-1 HI-MEG	REHV507B3X
R3	Potentiometer	5k, 10%, Linear	AB WA2G040S502UA	PTCC502B03
R4 (RO-3C)	Resistor	1M, 5%, 1/4 W		RECC105B22
R4 (RO-3D)	Resistor	200k, 5%, 1/4 W		RECC204B22
R5	Resistor	110k, 5%, 1/4 W		RECC114B22
R6, R7	Resistor	91k, 5%, 1/4 W		RECC913B22
R8	Resistor	10k, 5%, 1/4 W		RECC103B22
R9, R10, R11, R12	Potentiometer	10k, 10%, 1/2 W	AB WA2G024S103UA	PTCC103B33
R13 (RO-3C)	Resistor	130k, 5%, 1/4 W		RECC134B22
R13 (RO-3D)	Resistor	330k, 5%, 1/4 W		RECC334B22
R14	Resistor	2.4k, 5%, 1/4 W		RECC242B22
R15 (RO-3C)	Resistor	10M, 5%, 1/4 W		RECC106B22
R15 (RO-3D)	Resistor	820k, 5%, 1/4 W		RECC824B22
R16 (RO-3D)	Resistor	10M, 5%, 1/4 W		RECC106B22
S1	Switch	Rotary	Eberline 10695-B34	SWRO39

MODELS RO-3C/RO-3D

REF DESIG	PART	DESCRIPTION	MANUFACTURER AND PART NUMBER	EBERLINE PART NUMBER
S2, S3 S4	Switch Switch	Reed Toggle, Spring-loaded <i>OFF</i>	Eberline 10695-A54 C&K 7102SYZQ	SWRD1 SWTO17
		Desiccant, Indicating Silica Gel	No. 6-16B Eagle Chemical Company, P.O. Box 107 Mobile, Alabama	
		Conductive Coating Dag Dispersion	No. 154 Acheson Colloids Company Port Huron, Michigan 48060	
		Conductive Elastomer	Teknit 86-10075	
		Aluminized Mylar®, 1-mil-thick (0.001 inch)	Alexander Vacuum 278 Main Greenfield, Mass. 01301	

SECTION VI  
DIAGRAMS

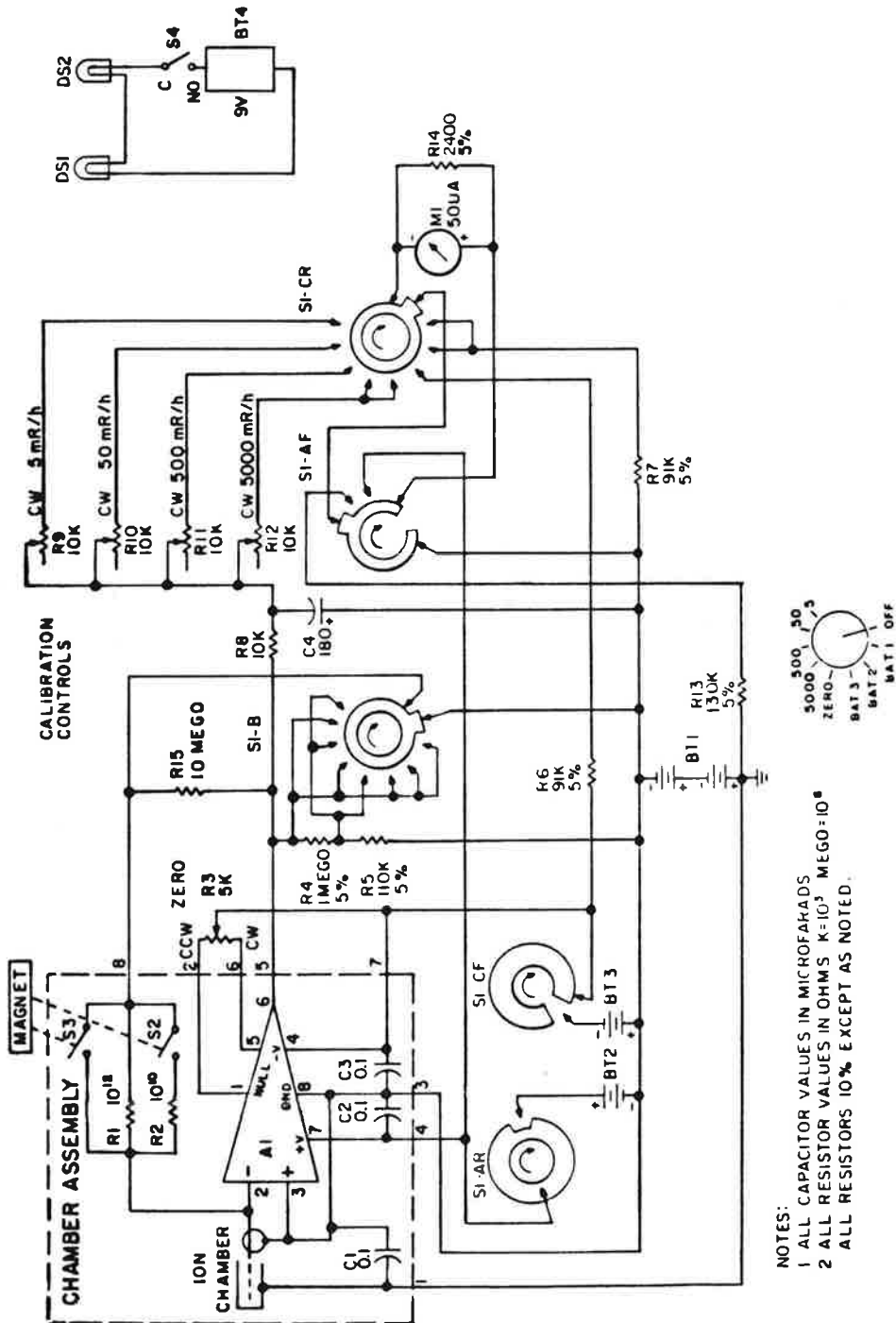

- NOTES:
- 1 ALL CAPACITOR VALUES IN MICROFARADS
  - 2 ALL RESISTOR VALUES IN OHMS K=10<sup>3</sup> MEGO=10<sup>6</sup>
  - ALL RESISTORS 10% EXCEPT AS NOTED.

Figure 6-1. Model RO-3C General Schematic (11252-B05)

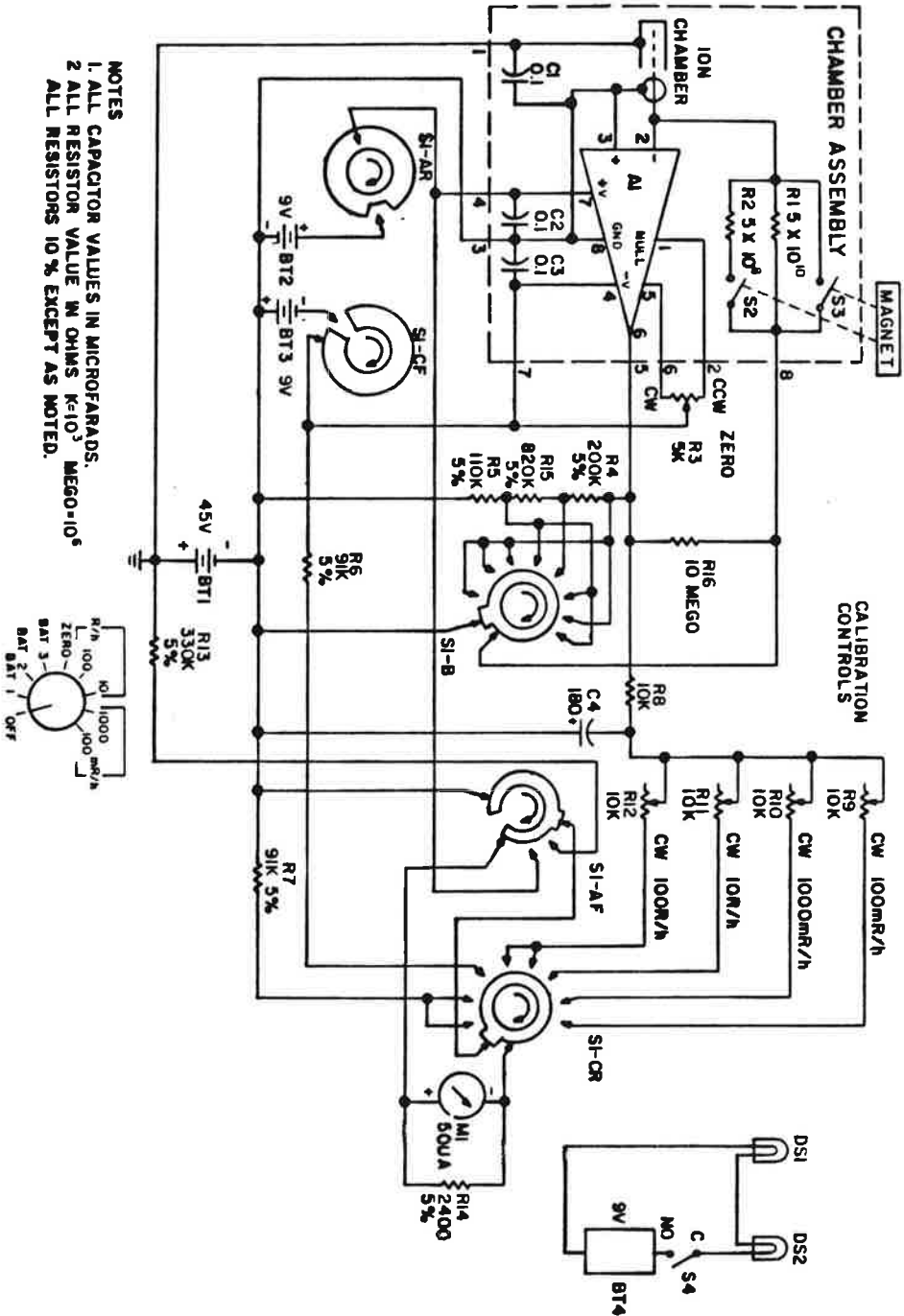

NOTES  
 1. ALL CAPACITOR VALUES IN MICROFARADS.  
 2. ALL RESISTOR VALUE IN OHMS K=10<sup>3</sup> MEGO=10<sup>6</sup>  
 ALL RESISTORS 10% EXCEPT AS NOTED.

Figure 6-2. Model RO-3D General Schematic (11253-B05)

MODELS RO-3C/RO-3D

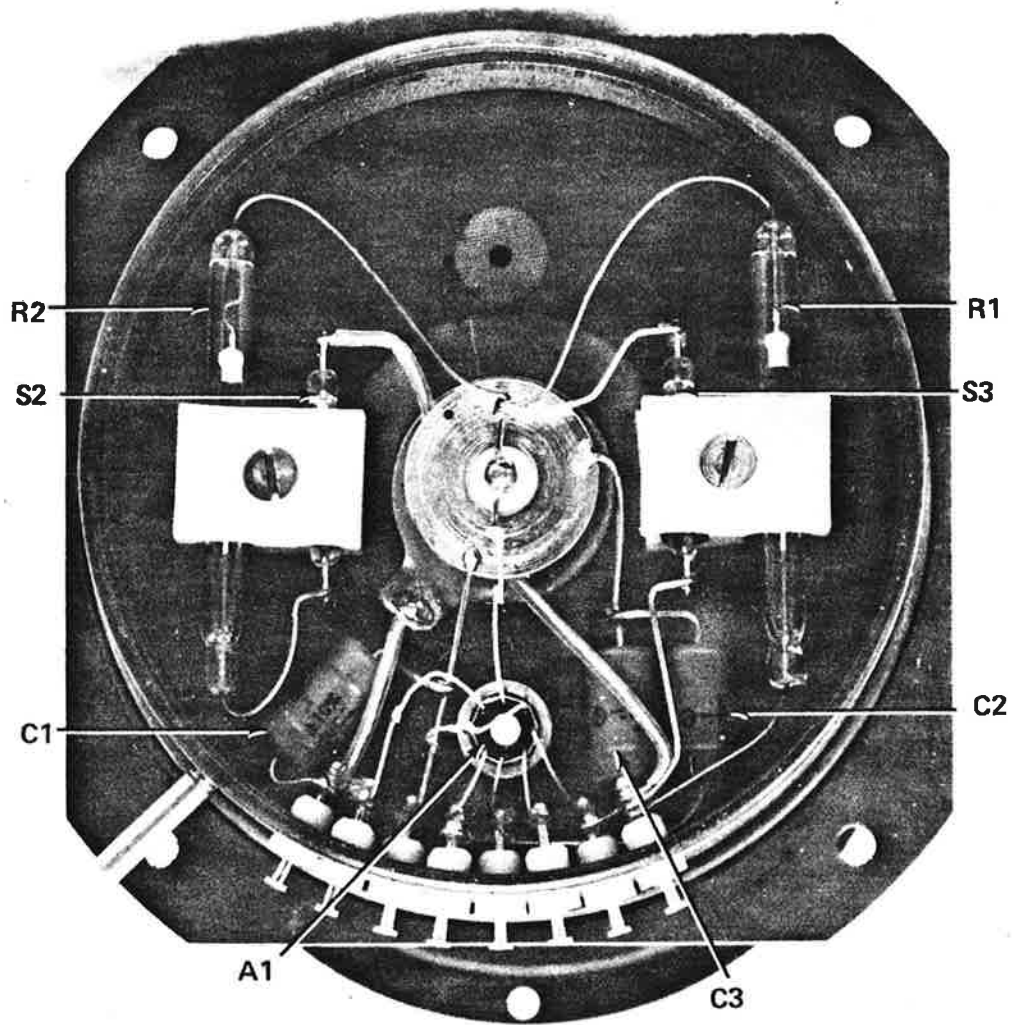

Figure 6-3. Models RO-3C/RO-3D Chamber Component Layout

# PHOTON ENERGY RESPONSE

EBERLINE

RO-3C

SN 164

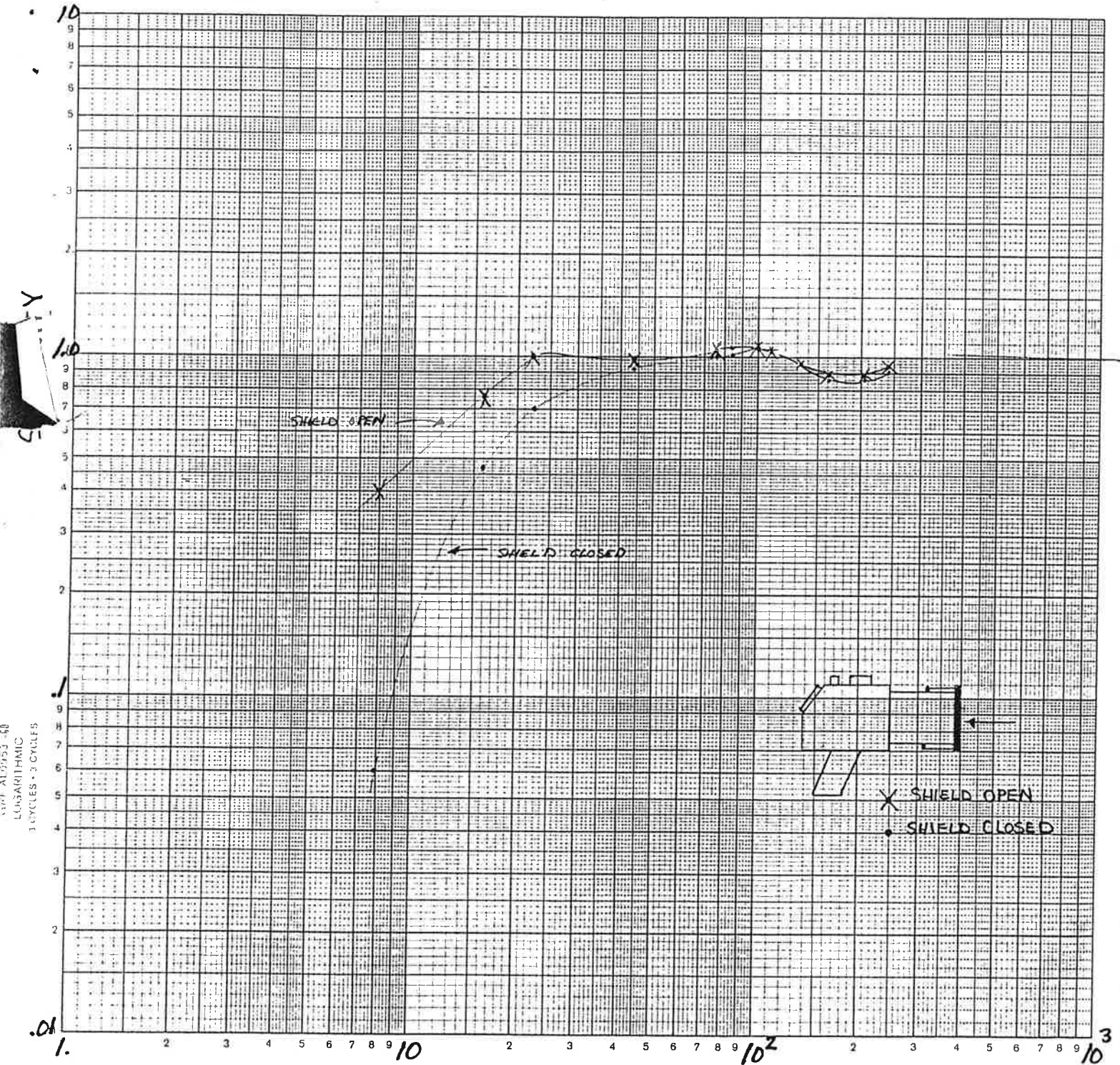

PHOTON ENERGY (KeV)